

ISUZU

MU-X



**STAND
OUT**

WWW.ISUZU.CO.KE



ISUZU
MU-X



**It Announces You
Better Than Your Title**

ISUZU
MU-X

Adventure Begins Here

From its legendary 3-litre turbo-diesel engine to unprecedented safety, comfort and off-road ability, the 7-seat Isuzu mu-X delivers like never before.

With seven seats, sleek urban style and a full suite of cutting-edge technology, the mu-X takes you to the next level. It's as eye-catching off-road as it is in the city, offering an unmatched combination of performance and reliability that's tailored to Kenyan conditions. With 3.5 tonne towing and seamless connectivity, it's both refined and robust. Wherever you're headed, the mu-X is your perfect travelling companion.

Everything Isuzu has learned in over a century of specialist engineering has led to this. The commanding, confident and capable Isuzu mu-X.





COMFORT AND CONVINIENCE

STYLE AND CONFIDENCE

A Compelling Combination Of Form And Function, The Isuzu mu-X Is As Confident In The City As It Is Off The Beaten Track.

The Isuzu mu-X catches the eye with a broad, bold grille that flows effortlessly into a decisively sculpted silhouette. It's shape is both muscular and modern. Longer, wider and even more distinctive, the mu-X makes a grand statement - wherever you go.

Ultra-bright Bi-LED headlights with LED Daytime Running Lights (DRLs) automatically light up the road ahead. Side steps add practicality and purpose for every trip. Both the 1.9L and 3.0L models boast exterior style with roof rails, chrome finishes and fog lights combined with sleek 18" tungsten silver alloy wheels with highway-terrain tyres.

As imposing as it is impressive, the mu-X is your invitation to adventure.

A. BI-LED HEADLIGHTS WITH DAYTIME RUNNING LIGHTS: Standard on every mu-X, brighter than ever with a signature design that takes style to new heights

B. 18" ALLOY WHEELS: Striking whether you're on tarmac or tackling tougher terrain, the mu-X's 18" alloys come standard on the 1.9L and 3.0L models.

C. LED TAIL LIGHTS: Standard across the range, LED tail lights offer better illumination and a distinctive lighting cluster.





COMFORT AND CONVENIENCE

COMFORT AND CONVENIENCE

Where Space Meets Style – And Craftsmanship Elevates Design.

Whether you're on the daily commute or traversing far corners of the country, the mu-X delivers comfort and convenience to every seat.

The mu-X's cabin has never been more advanced, boasting richly appointed seats with softer cushioning and firmer lateral support across the range along with built-in lumbar support on 3.0L models. LS-T models feature an eight-way electric adjustable driver's seat – and a four-way manual adjustable front passenger seat – each of which can be variably heated at the touch of a button. Multiple seating configurations mean ultimate comfort for up to seven occupants. While second row passengers enjoy a pair of USB charging ports via the centre console. All three rows have their own air-conditioning vents, while innovative touches, such as reclining second and third row seats, mean everybody wins. The mu-X is your new happy place – richly appointed, thoughtfully designed and technologically advanced, it's ready to go whenever you are.



A. 7-SEAT CAPACITY: The driver and up to six passengers can sit comfortably, including reclining seats in the second and third rows

B. ELECTRIC PARK BRAKE: Every mu-X comes standard with an Electric Park Brake and Auto Hold function, meaning the brake will initiate every time you put your mu-X in 'Park' or whenever your mu-X comes to a stop in traffic.

C. DUAL ZONE CLIMATE CONTROL: Enjoy the perfect temperature, even when opinions differ with dual zone climate control standard on 1.9L & 3.0L models.

D. FULL DARK LEATHER SEATS: Both driver and front-seat passenger enjoy a full dark leather trim.

E. TILT & TELESCOPIC STEERING WHEEL: All models feature a height and reach-adjustable steering wheel for improved comfort and control.





COMMAND CENTRE (COCKPIT)

INTUITIVE AND INSPIRED

The Isuzu mu-X Delivers The Perfect Balance Of Functionality And Technology.

Every mu-X features a large, high-definition, customisable central touchscreen, with digital radio, Android Auto™ and wireless Apple CarPlay®, as well as voice recognition. Trip planning in 1.9L & 3.0L models is simple, with built-in satellite navigation as standard. 3.0L model also features an auto-dimming rear view mirror and heated door mirrors. And if keeping track of the outside world is straightforward, so is keeping tabs on what's happening within – with an intelligent seatbelt reminder for all three rows as standard.

A hands-free power tailgate on 3.0L models allows you easy access to the rear storage space by activating the rear tailgate sensors by stepping in and out of the detection area or a simple push of a button on the smart key, the driver's seat or from the button on the tailgate. Push button start is standard across the range, while 1.9L & 3.0L models have the added convenience of passive entry on driver and front passenger doors. And every mu-X comes with an electric park brake with Auto Hold as standard. It activates independently whenever you select 'Park' in your mu-X or when you come to a stop in traffic – and disengages automatically once you select a gear or put your foot on the accelerator. It stops you from worrying about creeping forward in traffic or whether you've put your park brake on once you've left the vehicle.

Cutting-edge tech, designed with you in mind – the mu-X offers everything you could want from a modern SUV and more.

<p>A. REMOTE ENGINE START: The engine can be activated prior to entry with the push of a button. On 3.0L model only.</p>	<p>B. SMART MID: 4.2" full colour display relays vitals to the driver, such as speed zones, tyre pressure, fuel usage and range, digital speedometer and directions via satellite navigation (on 1.9L & 3.0L models).</p>
<p>C. REVERSING CAMERA: Reversing camera with dynamic guidelines, Rear Parking Sensors and Rear Cross Traffic Alert as standard.</p>	<p>D. APPLE CARPLAY & ANDROID AUTO: Android Auto™ and wireless Apple CarPlay® keeps you connected, with smartphone mirroring and voice-recognition for true handsfree connectivity.</p>
<p>E. HANDS-FREE POWER TAILGATE: Open or close the tailgate by activating the rear tailgate sensors by stepping in and out of the detection area or a simple push of a button on the smart key, the driver's seat or from the button on the tailgate. (Standard on 3.0L models).</p>	





SAFETY FEATURES ANCAP RATING

SMARTER AND SAFER

The Isuzu mu-X Enhances Your Driving Experience – And Your Safety – With Cutting-edge And Personalised Driver Assistance Systems.

All mu-X models have achieved a maximum 5-star ANCAP safety rating which covers an extensive list of both active and passive safety features.

The mu-X model includes seven airbags as standard and a stronger, more robust chassis, as well as a reinforced cabin safety cell for ultimate protection. The mu-X puts your safety first – wherever adventure takes you.



PERFORMANCE (THE MUSCLE UNDER THE HOOD)

POWER AND PERFORMANCE

With 190HP Of Power And 450Nm Of Torque, You've Never Been More Able To Go Your Own Way.

Isuzu's legendary 3-litre turbo-diesel common rail engine delivers unmatched dependability - and a deluge of torque on command. All 450Nm is available from just 1600rpm, providing maximum take-off and acceleration, while aboard, flat torque band aids drivability. With precise fuel injection control and low engine noise, improved aerodynamics and all the power you need, Isuzu's 7-seat SUV is more capable than ever.

Mated to a 'Rev-Tronic' automatic six-speed transmission with sequential sports mode, each mu-X demonstrates unprecedented sophistication across its drivetrain. Wherever you're going, the transmission seamlessly adapts to your driving style, automatically selecting the most appropriate shift and lock-up points according to road speed and vehicle load. Whether it's tackling terrain that others won't, tackling the weekend, or simply dealing with the daily demands of the city, the mu-X rises to every challenge.

A. ISUZU 3-LITRE and 1.9-LITRE ENGINES:
The advanced 3 Litre 4JJ3-TCX with plenty of real world power (190HP) and torque (450Nm).

The new 1.9 Litre RZ4E-TC with plenty of real world power (149HP) and torque (350Nm).

B. 6-SPEED TRANSMISSION:
The mu-X features 6-speed automatic.





TOWING (THE POWER TO MOVE)

FREEDOM AND ADVENTURE

With 190HP Of Power And 450Nm Of Torque, You've Never Been More Able To Go Your Own Way.

With the Isuzu mu-X, you've got the perfect traveling companion. The power and dependability of Isuzu's proven 3-litre turbo-diesel engine make light work of every journey, and a genuine Isuzu tow-bar kit will enable 3.5 tonne towing – whatever the terrain. And with Trailer Sway Control (TSC) as standard, the mu-X helps keep your load where it should be. Should it detect lateral movement due to high winds or on uneven road surfaces – TSC will automatically apply the brakes on individual wheels. Operating smoothly and without fuss, the system can help to keep your trailer from stepping out of line – and you on the road.

With an incredibly durable chassis and suspension tuned for Kenyan conditions, the mu-X is built for adventure. And with an increased 80-litre fuel tank, it's ready to go the extra mile. There is also a range of towing-specific Isuzu accessories, such as an electronic brake controller or weight distribution hitch, to give you ultimate control over your load.

A. TRAILER SWAY CONTROL (TSC):
Will apply brakes to individual vehicle wheels to help bring the trailer safely back under control.

B. OPTIONAL 2-PIN TOW HARNESS:
Convenience when towing.

C. OPTIONAL TOW BAR RECEIVER:
You will be able to tow up to 3.5 tonnes when paired with a genuine tow tongue kit and optional genuine 7-pin or 12-pin wiring harness.

D. OPTIONAL ELECTRONIC BRAKE CONTROLLER:
Maintain precise control of your heavy caravan or trailer's brakes from the comfort of the driver's seat.





ENGINE (THE TOUGH ISUZU DNA)

UNRIVALED HERITAGE

Isuzu's Reputation For Reliability Stretches Back Over a Century. The Isuzu mu-X is A New Standard Bearer For Comfort And Strength.

Dependability is a fundamental part of the mu-X DNA. Having built more than 26 million engines internationally, Isuzu is the world leader in precision diesel engineering. The second-generation mu-X builds on that record, bringing an even higher level of technology and utility to a rugged platform that's proven in the toughest conditions.

The mu-X's chassis is constructed with high-tensile steel with an extra crossmember for added reliability. Independent double-wishbone front suspension with higher control arms improve handling for a more comfortable ride, while the rear coil spring suspension improves overall load-carrying, flexibility and drivability. A lightweight body provides greater overall stability and greater occupant protection, as well as reduced noise and vibration throughout.

For even greater long-term peace of mind, every mu-X comes with Isuzu Service Plus – offering a 3 year/100,000km warranty and servicing.

A. STEEL TIMING CHAIN:

The steel timing chain found in the Isuzu engine is sturdier and lasts longer than a standard poly belt.

B. PISTONS

Piston crowns and pins are coated with a special diamond-like carbon that improves durability and heat resistance, helping the engine work smoothly at maximum power

C. FRONT SUSPENSION:

Higher mounted control arms minimise body roll when cornering and improve tyre grounding.

D. REAR COIL SPRING SUSPENSION:

A lighter, but stronger coil spring with 5 linkage independent suspension designed for Kenyan conditions creates a smoother ride.

E DOUBLE SCISSOR GEARS:

A double scissor idler gear design results in reduced engine and gear noise for quieter and smoother operation.





OFFROAD (THE ROAD LESS TRAVELLED)

EXPLORE AND CONQUER

The Isuzu mu-X Is Built To Conquer Kenya's Toughest Terrain in Ultimate Comfort – And Minimal Fuss. Because Life Begins Off The Beaten Path.

With up to 800mm wading depth, extensive steel and poly-composite underbody protection and a rear axle differential lock as standard on every 4x4 model, the mu-X comes alive when you leave the bitumen behind. Ever-willing and incredibly capable, it's been developed to adapt to whatever challenge you decide to take on.

Engineered for Kenyan conditions, every 4x4 mu-X features 'Terrain Command' mode as standard, allowing you to switch between 2WD-high and 4WD-high modes at speeds of up to 100km/h in less than a second. Providing a new lease on traction when off-road, all 4x4 mu-X models feature 'Rough Terrain Mode', an off-road based electronic driver aid that maximises drivability in technical, slippery and rough conditions. Hill Descent Control (HDC) provides maximum control on difficult descents, while Hill Start Assist (HSA) automatically prevents roll-back when starting on steep gradients (above 5.7 degrees). And once you've stopped, an electric park brake means your mu-X isn't going anywhere – until you want it to.

A STEEL UNDERBODY PROTECTION:

Steel underbody guards the sump and transfer case on 4x4 models.

B 800MM WADING DEPTH:

Water crossings are simple with a wading depth of 800mm on all mu-X models.

C REAR DIFFERENTIAL LOCK:

Standard on all 4x4 models, the rear e-differential lock can be engaged with the push of a button when in 4WD-low.

D TERRAIN COMMAND DIAL:

Switch quickly and easily between 2WD-high, 4WD-high and 4WD-low driving modes.



A

B



C



D



**DYNAMIC AND
DEPENDABLE**

An Unbeatable Combination Of Reliability, Technology, Economy And Comfort, The Isuzu mu-X Is The Ideal Solution To Your Fleet Needs.

There are work vehicles, and then there's the mu-X. Equipped with side steps, push button start, and alloys across the range - as well as Android Auto™ and wireless Apple CarPlay® - it's built to be a comfortable and functional mobile office. Bringing fuel efficiency and reliability to the fore, it's been engineered to spend more time on the job - and less time being serviced.

Isuzu East Africa has a Dealer network of over 60 authorised service outlets covering every corner of East Africa to ensure that support is always close to you.

Our dedicated team of fleet managers are always available to ensure that all your requirements are met





**YOU DESERVE
PEACE OF MIND**

The Extra Mile Support

Warranty and Service:

100,000KM or 3 Years, whichever comes first

ISUZU Genuine Service -

With a comprehensive network covering East Africa, your local Isuzu service center will keep your mu-X performing at its best - wherever you find yourself.

ISUZU Genuine Parts -

Because every part of your mu-X matters, the parts are designed and tested to provide the highest quality and durability.

ISUZU Accessories -

They provide another way to enhance and personalize your mu-X with the confidence of Isuzu.





ACCESSORIES

OPPORTUNITIES AND EXPERIENCES

/ Standard Accessories



STANDARD

CARPET FLOOR MAT

PN:5867611641

PRICE:Kes. 22,389

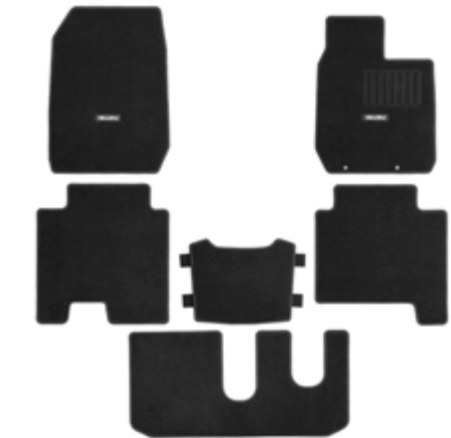

STANDARD

RUBBER FLOOR MAT

PN: 5867638151

PRICE: Kes. 10,198



STANDARD

DOOR VISOR

PN:5867640782

PRICE: Kes. 12,659



ACCESSORIES

OPPORTUNITIES AND EXPERIENCES

/ Optional Accessories



OPTIONAL

MUFFLER CUTTER

PN:5867641270

PRICE: Kes. 6,629



OPTIONAL

DOOR HOUSING PROTECTOR

PN:5867630721

PRICE: Kes. 8,159



OPTIONAL

CARGO LINER

PN:5867641120

PRICE: Kes. 23,321



OPTIONAL

REAR BUMPER GARNISH

PN:5867635730

PRICE: Kes. 12,518



OPTIONAL

CARGO NET

PN:5867641080

PRICE: Kes. 19,755



OPTIONAL

ROCKER PLATE

PN:5867630801

PRICE: Kes. 9,688



COMFORT AND CONVINIENCE

COLOURS AND TRIMS

Body Colors



Onyx Black Mica



Sapphire Blue Mica



Norwegian Blue Mica



Red Spinel Mica



Santos Brown Mica



Mercury Silver Metallic



Splash White



Obsidian Grey Mica



Dolomite White Pearl



Vehicle Specifications

ENGINE		3.0 LITRE
Drive, Transmission	4X4, Automatic	
Code	4JJ3-TCX	
Type	3.0L, In-line 4-cylinder common-rail direct fuel injection with intercooled Variable Geometry System turbo charger	
Displacement (cc)	2,999	
Max Power kW(PS)/rpm*	140 (190) / 3,600	
Max Torque Nm(kgm)/rpm*	450 (45.9) / 1,600 - 2,600	

TRANSMISSIONS	
Type	6-speed auto

SUSPENSION SYSTEM	
Front	Independent, coil springs, gas shock absorbers, upper & lower wishbones, stabiliser bar
Rear	Five-link coil suspension, gas shock absorbers, stabiliser bar
Brake system -Front & Rear	Ventilated front disc 17" with twin piston callipers

TYRES & WHEELS	
Tyres	265/60 R18 (H/T Pattern)
Wheels	18" x 7.5J Alloy
Spare Tyre	18" Alloy

WEIGHT, CAPACITIES & DIMENSIONS	
Length (mm)	4,850
Width (mm)	1,870
Height (mm)	1,822
Ground clearance (mm)	227
Seating capacity (persons)	7
Fuel Tank capacity (litre)	80

EXTERIOR FEATURES	
Exterior mirrors	Power Adjustable, Retractable
Side steps	Equipped
Mudflaps	Front & Rear
Daytime running lights (DRL)	LED
BI-LED Headlights with "on" warning buzzer, Rear LED combination tail-lights, Luggage lamp	Equipped
Fuel Tank capacity (litre)	80

INFOTAINMENT	
CD Frontloader, USB, auxiliary, Steering Wheel Controls and Bluetooth	Equipped with 9 inch full color touch screen
No Of Speakers	8

INTERIOR FEATURES	
Power Assisted Steering (PAS)	Equipped
Height adjustable steering column	Manual / Tilt
Leather steering wheel with multifunction controls	Equipped
Seat trim	Leather
Seating capacity	7
Driver's Seat Adjustable	Power Assist - Six-way adjustable electric
Air conditioner	Automatic Climate Control , dual zone with rear cabin cooling vents
Sun visor vanity mirror	Driver & Passenger with Vanity Mirror & Driver Ticketholder
Multi Information Display (MID), Dashboard illumination control	Equipped
Cruise Control	Equipped
Electrically operated windows	All with Driver Auto Up/Down with Jam Protection & Timer
Door trim with storage pockets and integrated cupholders	Equipped
Fixed rear window, with defogger	Equipped
Interior courtesy lights	Equipped
High-mounted centre stop light	LED
Front reading lights	Equipped

SAFETY	
ABS Brakes, Electronic Brake-force Distribution (EBD), Emergency Brake Assist, Electronic Stability Control (ESC), Hill Descent Control (HDC)	Equipped

SAFETY	
Variable Speed Intermittent Wipers	Equipped with Rain sensing wipers
Airbags	7- Dual front airbags (driver + passenger), roof rail, and side airbags, Knee
Fog Lamps - Front	Equipped
Fog Lamps - Rear	Equipped
Front Headlamp Levelling	Automatic
Rear LED Tail Lamps	Equipped
Side Impact Protection Bars	Equipped
Height adjustable 3-point seatbelts	Equipped
ISOFIX Child Seat Anchorage	Equipped - 2nd Row Seat Outside & Centre
High Level Brake Light	Equipped
Rear Park Assist	Equipped - Rear Camera
Anti-theft Alarm, transponder Immobiliser & Keyless Entry, Remote Central Locking and Speed Sensing Automatic Door Lock	Equipped + Remote start Engine
Passive Entry and Start System (Push Button)	Equipped
Follow Me Home Headlamps	Equipped
ESS (Emergency Stop Signal)	Equipped
Walk Away Auto Door Lock	Equipped
LSD/Difflock	Difflock Equipped



Vehicle Specifications

ENGINE		1.9 LITRE
Drive, Transmission	4X4, Automatic	
Code	RZ4E-TC	
Type	1.9L, In-line 4-cylinder common-rail direct fuel injection with intercooled Variable Geometry System turbo charger	
Displacement (cc)	1,899	
Max Power kW(PS)/rpm*	110 (149) / 3,600	
Max Torque Nm(kgm)/rpm*	350 (35.7) / 1,800 - 2,600	

TRANSMISSIONS	
Type	6-speed auto

SUSPENSION SYSTEM	
Front	Independent, coil springs, gas shock absorbers, upper & lower wishbones, stabiliser bar
Rear	Five-link coil suspension, gas shock absorbers, stabiliser bar
Brake system -Front & Rear	Ventilated front disc 17"with twin piston callipers

TYRES & WHEELS	
Tyres	265/60 R18 (H/T Pattern)
Wheels	18" x 7.5J Alloy
Spare Tyre	18" Alloy

WEIGHT, CAPACITIES & DIMENSIONS	
Length (mm)	4,850
Width (mm)	1,870
Height (mm)	1,822
Ground clearance (mm)	227
Seating capacity (persons)	7
Fuel Tank capacity (litre)	80

EXTERIOR FEATURES	
Exterior mirrors	Power Adjustable, Retractable
Side steps	Equipped
Mudflaps	Front & Rear
Daytime running lights (DRL)	LED
BI-LED Headlights with "on" warning buzzer, Rear LED combination tail-lights, Luggage lamp	Equipped
Fuel Tank capacity (litre)	80

INFOTAINMENT	
CD Frontloader, USB, auxiliary, Steering Wheel Controls and Bluetooth	Equipped with 7 inch full color touch screen
No Of Speakers	6

INTERIOR FEATURES	
Power Assisted Steering (PAS)	Equipped
Height adjustable steering column	Manual / Tilt
Leather steering wheel with multifunction controls	Equipped
Seat trim	Leather
Seating capacity	7
Driver's Seat Adjustable	Manual Assist - Six-way adjustable
Air conditioner	Automatic Climate Control , dual zone with rear cabin cooling vents
Sun visor vanity mirror	Driver & Passenger with Vanity Mirror & Driver Ticketholder
Multi Information Display (MID), Dashboard illumination control	Equipped
Cruise Control	-
Electrically operated windows	All with Driver Auto Up/Down with Jam Protection
Door trim with storage pockets and integrated cupholders	Equipped
Fixed rear window, with defogger	Equipped
Interior courtesy lights	Equipped
High-mounted centre stop light	LED
Front reading lights	Equipped

SAFETY	
ABS Brakes, Electronic Brake-force Distribution (EBD), Emergency Brake Assist, Electronic Stability Control (ESC), Hill Descent Control (HDC)	Equipped

SAFETY	
Variable Speed Intermittent Wipers	Equipped with Rain sensing wipers
Airbags	7- Dual front airbags (driver + passenger), roof rail, and side airbags, Knee
Fog Lamps - Front	Equipped
Fog Lamps - Rear	-
Front Headlamp Levelling	Automatic
Rear LED Tail Lamps	Equipped
Side Impact Protection Bars	Equipped
Height adjustable 3-point seatbelts	Equipped
ISOFIX Child Seat Anchorage	Equipped - 2nd Row Seat Outside & Centre
High Level Brake Light	Equipped
Rear Park Assist	Equipped - Rear Camera
Anti-theft Alarm, transponder Immobiliser & Keyless Entry, Remote Central Locking and Speed Sensing Automatic Door Lock	Equipped
Passive Entry and Start System (Push Button)	Equipped
Follow Me Home Headlamps	Equipped
ESS (Emergency Stop Signal)	Equipped
Walk Away Auto Door Lock	Equipped
LSD/Difflock	Difflock Equipped

VEHICLE DIMENSIONS

Vehicle Dimensions

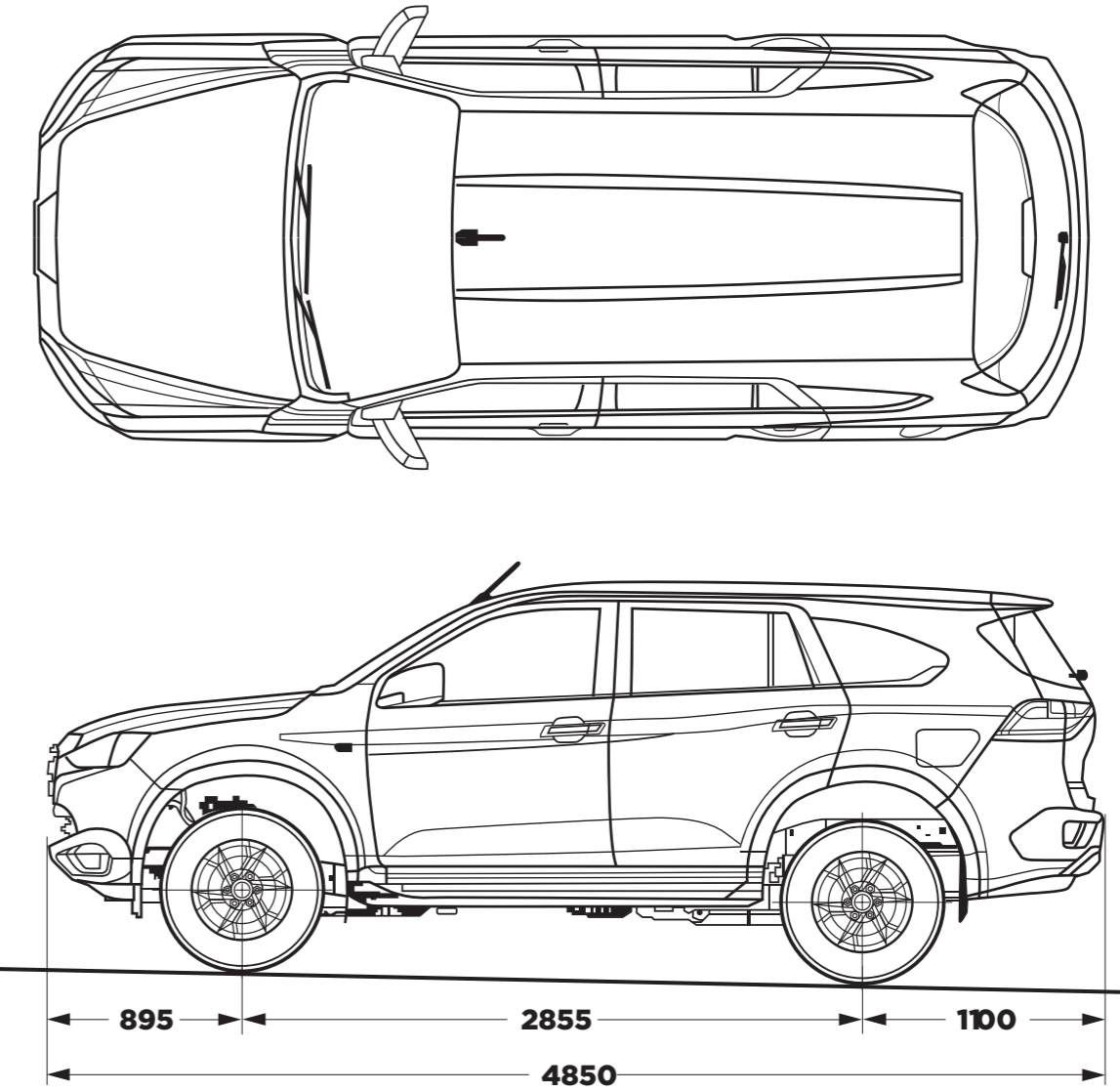
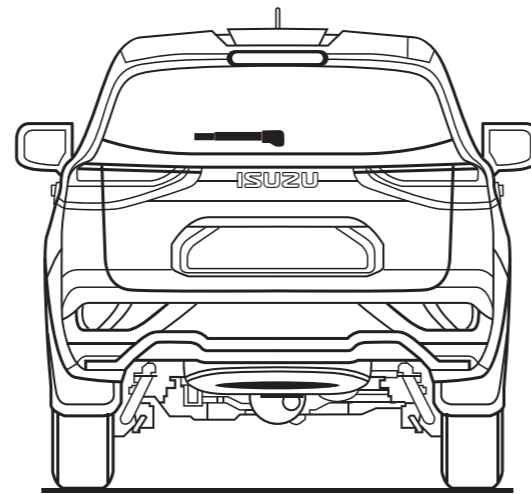
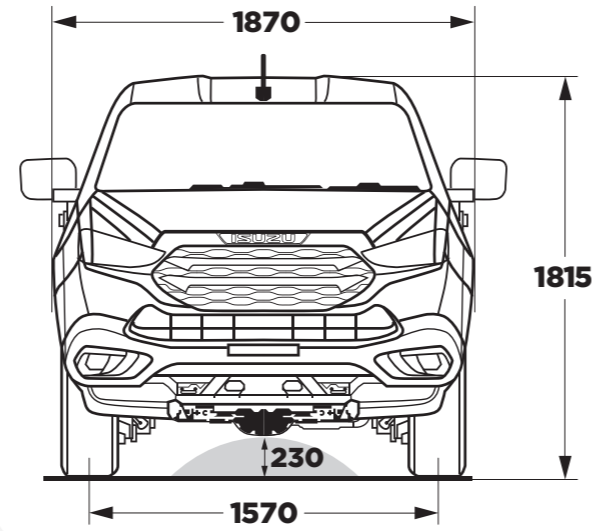

ISUZU
MU-X



MU-X

CONTACT US



0800 724 724



info.kenya@isuzu.co.ke



Isuzu East Africa Ltd,
Enterprise Road, off Mombasa Road
P.O. Box 30527 Nairobi GPO,
00100 Kenya, East Africa